

LIUGONG
NORTH AMERICA

856HE

WHEEL LOADER

BATTERY TYPE
LFP

OPERATING WEIGHT
21,000 lb
(46,297 kg)

RATED STORAGE ENERGY
423 kWh

BUCKET CAPACITY
4.58 yd³
(3.5 m³)



SPECIFICATIONS

POWER BATTERY

Battery type	Lithium iron phosphate batteries
Drive motors & hydraulic motors	INOVANCE
Manufacturer	CATL
Model	LFP
Rated storage energy	432 kWh
Nominal voltage	618 V
Protection class of battery system	IP67
Cooling method	Intelligent temperature control, liquid cooling
Optional charging pile specifications	≤ 482.8 hp (≤360 kW)
Charging time (300 kW charging pile)	≤90 min (fast charging)

DRIVE MOTOR

Power	160 kW (215 hp)
Ambient temperature	-40-185°F (-40-85°C)
Adaptive altitude	≤5,000 m (3.1 mile)

HYDRAULIC SYSTEM

Main pump type	Variable displacement pump
System pressure	3,626 psi (25 MPa)
Controls	Electric proportional fingertip control
Raise	5.2 s
Dump time	1.5 s
Float down time	2.3 s
Total cycle time	9.0 s

ELECTRICAL SYSTEM

Voltage	DC 24 V
Batteries	2×12 V
Battery capacity at 20h rate	120 Ah
Cold cranking capacity at (-18 °C)	850 A
Reserve capacity at (-44 °F)	224 min

TRANSMISSION

Transmission type	Planetary, power shift
Number of speeds, fwd	2
Number of speeds, rev	1
Max. travel speed, fwd	24.9 mph (40 km/h)
Max. travel speed, rev	8.1 mph (13 km/h)

AXLES

Front and rear axle reduction ratio	23.3
Axle oscillation	±9°

STEERING

Steering configuration	Articulated
Steering pressure	3,046 psi (21 MPa)

BRAKES

New electro-hydraulic proportional braking system

Service brake type	Full hydraulic
Parking brake type	Drum
Parking brake actuation	Hydraulic cylinder brake

BUCKET PERFORMANCE

Bucket capacity	3.53-7.32 yd ³ (2.7-5.6 m ³)
-----------------	---

TIRES

Tire size	23.5R25 L-3
-----------	-------------

OPERATING WEIGHT

Operating weight	46,297 lb (21,000 kg)
------------------	-----------------------

SERVICE CAPACITY

Cooling system	12 gal (45 L)
Hydraulic system	61 gal (230 L)
Transmission	8 gal (30 L)
Axles, front/Rear	9 gal (35 L)

SPECIFICATIONS

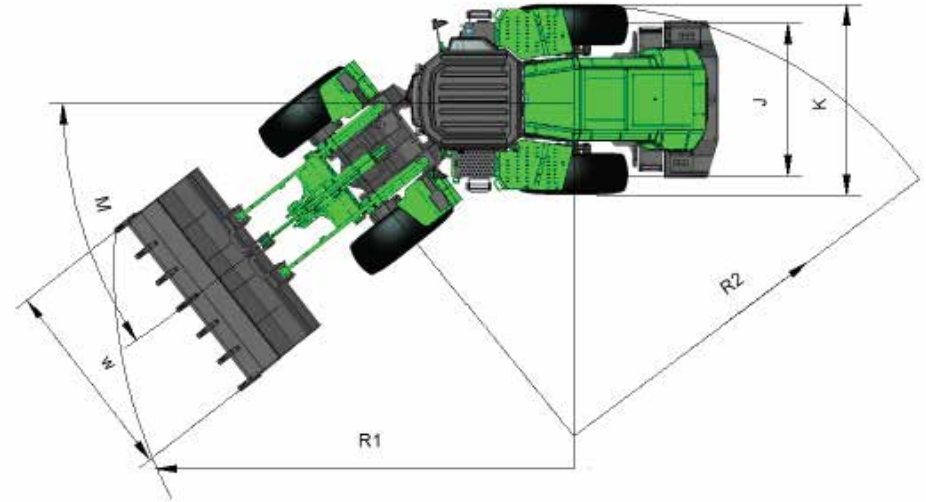
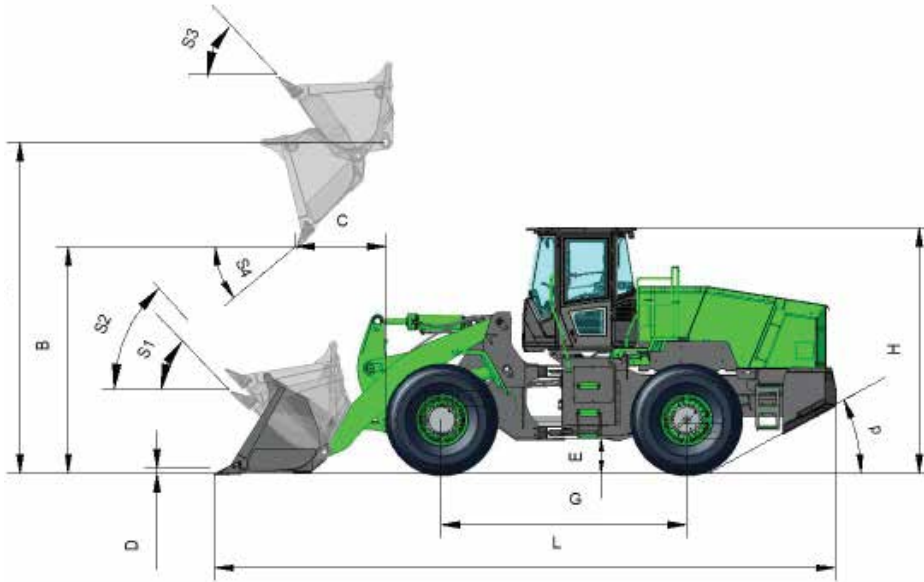

LOADER ARM PERFORMANCE WITH ATTACHMENT

Description	
Tipping load - straight	38,360 lb (17,400 kg)
Tipping load - full turn	33,951 lb (15,400 kg)
Bucket breakout force	36,419 lbf (162 kN)
A Maximum hinge pin height	13 ft 8 in (4,156 mm)
B Dump clearance at full height discharge	9 ft 9 in (2,977 mm)
C Dump reach at full height discharge	4 ft 0 in (1,231 mm)
D Max. digging depth, bucket level	2 in (50.2 mm)
S ₁ Bucket rollback at ground level	44.3°
S ₂ Bucket rollback at carry	49°
S ₃ Bucket rollback at max. height	56.3°
S ₄ Max. dump angle at full height	45°

DIMENSIONS

Description	
E Ground clearance	1 ft 5 in (431 mm)
G Wheelbase	11 ft 7 in (3,525 mm)
H Cab height	11 ft 6 in (3,500 mm)
J Wheel tread	7 ft 6 in (2,280 mm)
K Width over tires	9 ft 5 in (2,880 mm)
L Length with bucket down	28 ft 3 in (8,615 mm)
M Turn angle, either side	38°
P Rear angle of departure	28°
R ₁ Turning radius, bucket carry	23 ft 8 in (7,209 mm)
R ₂ Turning radius, outside of tire	21 ft 9 in (6,625 mm)
W Width over bucket	9 ft 9 in (2,970 mm)

EXCLUSIVELY FOR DEALER

KF M@, RR, 745GDL @W1/ 12/ 1, DMF , TR

Specifications and designs are subject to change without notice.
Machines shown may include optional equipment.

LiuGong Construction Machinery N.A., LLC.
22220 Merchants Way - Suite 100
Katy, TX 77449
USA

T: 281-579-8882 F: 281-579-8388
www.liugongna.com