

# MH-60

Material Handler

ENGINE  
Cummins  
X12

OPERATING WEIGHT  
119,400 lbs  
(54,200 kg)

GROSS POWER  
400 hp  
(298 kW)

MAX REACH  
60 FT

BALDOR GENERATOR  
33 kW



# SPECIFICATIONS

## ENGINE

Emissions rating	EPA Tier 4 Final
Make	Cummins
Model	X12
Aspiration	Turbo charged, charge air cooled
Cooling fan drive	Reversible direct drive fan
Displacement	720 cu.in. (11.8L)
Gross power	400HP (298kW)@2100
Peak torque	2,034 N-m (1,500 lb-ft) @ 1,400 rpm
Cylinders	In-line, 6 cylinder HPCR
Bore x Stroke	132mm x 144mm (5.20 in x 5.67 in)

## HYDRAULIC SYSTEM

## KAWASAKI

### Hydraulic piloted joysticks for simplicity (no laptop needed)

Pump Type	Dual Axial Piston Pump
Maximum flow	2x380 L/min
Max Pressure	4975 psi (34.3 mpa)
Hydraulic tank	76.6 gal.
Filtration	Dual Filtration System

**All pressures can be accessed through the cab display. No special gauges needed.**

## UPPER CARRIAGE

The upper structure is strongly reinforced using an H-beam in the high cross section of main structure providing even weigh distribution and increasing stability. The platform's collision protection system has been welded into place to improve its strength, rigidity, and overall service life.

## TRAVEL / UNDERCARRIAGE

Type/ Drive System	All Wheel Drive variable displacement motor with dual stage power shift transmission
Travel Speed	1st 0 -4mph (0-7 km/h)   2nd 0-14 mph (23 km/h)
Tires	12.00-24/8.50 (solid rubber)
Steering	Joystick steering
Rear Axle	Fixed
Front Axle	Oscillating with hydraulic lock, integrated safety check valves
Service Brake	Disc brakes
Parking Brake	Multidisc brake , spring loaded
Safety	Travel Alarm

## SWING SYSTEM

Drive	2 x axial piston motor driving planetary gearbox, integrated brake vales
Swing speed	12 rpm
Swing Hydraulic	open loop
Swing Brake	multi-disc brake, spring loaded
Swing Bearing	internal teeth, sealed bearing

## Refill Capacities

Fuel tank	171 gal
Engine cooling system	13.2 gal
Engine oil w/filter	8.98 gal
Hydraulic tank	76 gal
Hydraulic system	124.2 gal
Swing motor (each)	1.4 gal
Axle hub (front)	.31 gal
Axle hub (rear)	.39 gal
Axle differential (front axle)	6.9 gal
Axle differential (rear axle)	5.1 gal
Axle transmission	.8 gal
Swing ring lubrication reservoir	.26 gal
Central lubrcication reservoir	5.5 lb
Diesel exhaust fluid.	7.93 gal

## ELECTRIC SYSTEM

System voltage	24 Volt
Battery	2 x 12 V, 120 Ah
Alternator	24v-70A

## OPERATING WEIGHT

Operating Weight, typical	119,400 lb
---------------------------	------------

## CENTRAL AUTO LUBE

## GROENEVELD-BEKA

## BALDOR GENERATOR

## 33 kW

## HUBBELL CONTROLLER

## HC58441-090

## LGNA-SS-MH60-202308-ENG-US

Specifications and designs are subject to change without notice. Machines shown may include optional equipment.

LiuGong Construction Machinery N.A., LLC.  
22220 Merchants Way - Suite 100  
Katy, TX 77449  
USA

T: 281-579-8882  
www.liugongna.com

F: 281-579-8388

# SPECIFICATIONS

DEALER INFORMATION HERE

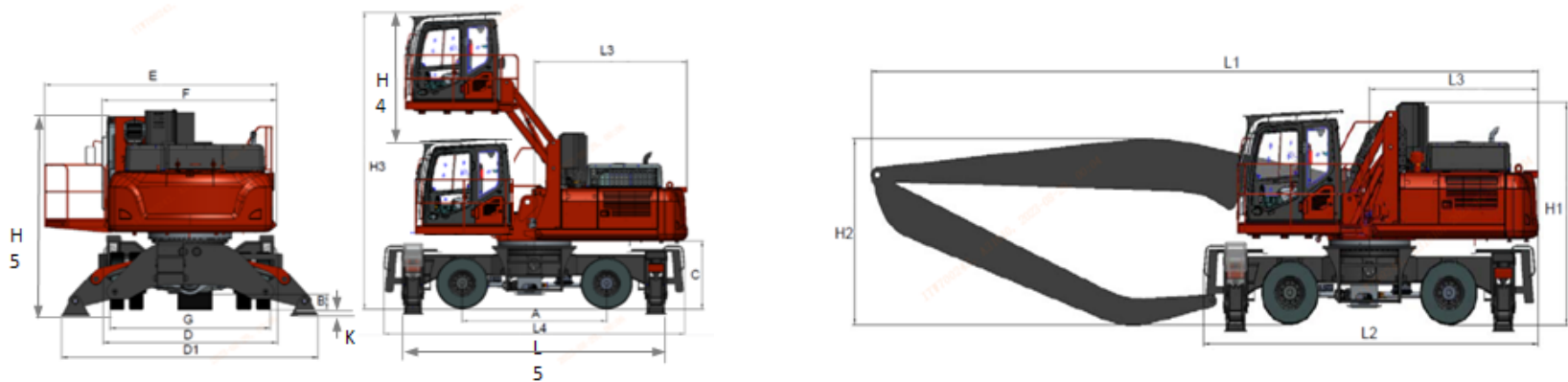

## DIMENSIONS

Description	DATA
A Wheelbase	11'8
B Ground Clearance	8"
C Counterweight Clearance	5
D Undercarriage width	12'1
D1 Undercarriage width (all outrigger extended)	18
E Width of upper structure (with operator catwalk)	14'4W
F Width of upper structure (without operator catwalk)	10'2
G Track width (outside to outside)	12'
H1 Overall height (with Generator)	14'
H2 Boom height	14'
H3 Cab height (Raised)	21'3
H4 Cab Raised height	8'10
K Wheel clearance (all outrigger extended)	4"
L1 Overall length (with front)	47'9
L2 Overall length (without front)	25'
L3 Rear end length	11'9
L4 Undercarriage length	25'
L5 Undercarriage length (outrigger to outrigger)	21'

## DIMENSIONS

Description	DATA
Overall width of machine (transportation)	13'8
Boom Length	35'
Stick Length	24'
Maximum Reach Radius	60'
Ambient Operating Temperature	"-23°C to 45°C (-9.4°F to 113° F)"

## LGNA-SS-MH60-202308-ENG-US

Specifications and designs are subject to change without notice. Machines shown may include optional equipment.

LiuGong Construction Machinery N.A., LLC.  
22220 Merchants Way - Suite 100  
Katy, TX 77449  
USA

T: 281-579-8882  
www.liugongna.com

F: 281-579-8388

# MH 60 LOAD CHART

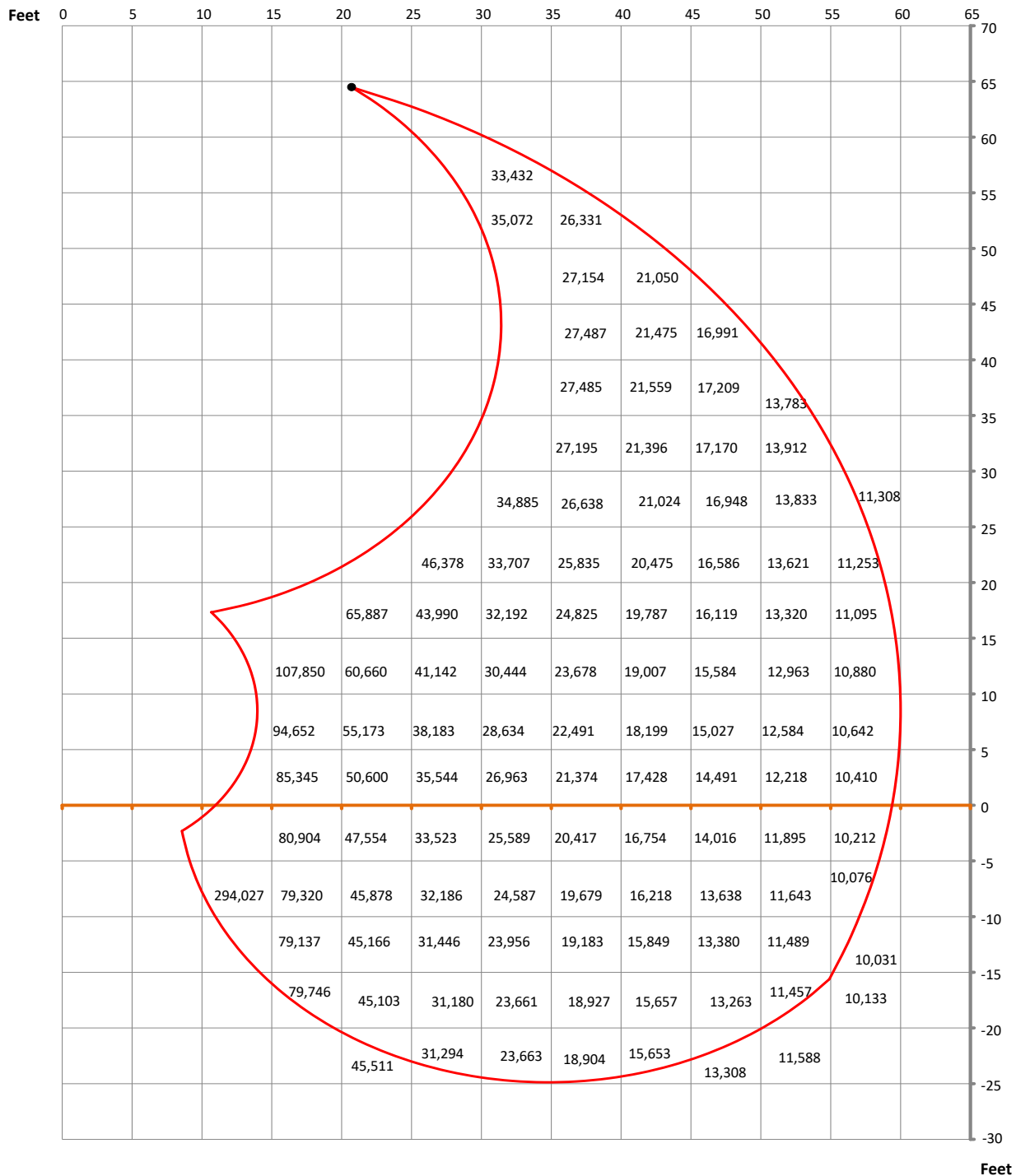

The load capacity number is in unit of pounds and the location is the left upper corner of the box. For example box 33,432 lbs is the load capacity at 30 ft reach and 60 ft height. The reach measurement is from the center point of the rotation bearing to the load point. The height is measured from the load point to ground. The load point is the center line of the attachment pivot mounting pin on the stick.

The load capacities are based on ISO 10567 and do not exceed 75% of tipping and 87% of hydraulic capacity and machine standing on firm, level supporting surface. Loads are valid for 360° with machine support outriggers. Lifting capacities do not include working equipment such as orange-peel grapples, magnets, clamshells, etc. Attachment weights must be deducted from the numbers indicated in the lift chart. Please contact LiuGong or your local dealer for optimum attachment selection. The operator of the machine should be fully acquainted with the operator's manual provided by LiuGong. Capacities apply only to the machine as originally manufactured and equipped by LiuGong.